

# DSI3200 SSD Installation Instructions for MCP Hosts

## Hardware Installation

Follow the basic instructions in the manual included with the unit. The unit connects to the host with Short Wave (SW) Fibre Optic cables. For NX systems, the cables connect to either FCA662-SW or FCA622-SW channels. For LX and CS systems, the cables connect to the current Unisys Short Wave Fibre Channel Adapter.

## DSI3200 Configuration

DSI will pre-configure the DSI3200 for the customer if the customer configuration requirements were received prior to shipment. There will be a configuration sheet included with the unit that specifies how the unit was partitioned including the addresses and LUNs for those partitions. If configuration changes need to be made in the field, an appropriate TCPIP address will need to be configured via the front panel. The unit may then be accessed via Web Browser, HyperTerm or other PC terminal emulator (NOT T27 style emulators).

The DSI3200 SSD unit has a block of memory, which may be partitioned up to 64 times. Each partition is assigned a number starting at 0 and increasing by 1 for each partition. This partition number is also known as the LUN (Logical Unit Number). The DSI3200 will also have up to 4 Short Wave Fibre Channel interface cards at the back of the unit. Each interface card has 2 Fibre Channel ports. The right most interface card has port 1a (left side) and port 1b (right side). The ports on the other (if ordered) cards are 2a,2b – 3a,3b – 4a,4b going in order from right to left. Each port can be assigned a single Fibre Channel address. The LUNs are then assigned to one or more of the ports.

## PCD

The PCD for a Unisys MCP system will depend on the configuration of the DSI3200 as described above. The following guidelines should help in creating a PCD for the DSI3200.

## Channel

The DSI3200 can be connected to the Unisys FCA622-SW or FCA662-SW on NX systems, the FCA1850-LC on Libra systems, or the current Fibre Channel adapter used on LX, CS, and FS systems. The address of the channel should be in the range 125 – 118. Other channel parameters will be installation configuration based.

## Control (CTL)

Each port on the DSI3200 accessed by the MCP host must have a corresponding Control defined in the PCD. In this discussion, the terms Port and Control are synonymous. Ports accessed by other hosts (MCP or otherwise) do not need to be declared in this PCD. Controls are declared with addresses of 0 – 117 usually starting with the lower numbers. The address declared for a Control must match the address configured for the DSI3200 port to which it is cabled. Controls

are declared with a device type of FCSCSI1. For most sites, there will only be one Control declared per Channel site and the cabling will be arbitrated loop (FCAL). Fibre Channel Point to Point/Fabric Aware configurations are not yet supported on MCP systems.

### Unit

Each partition (LUN) accessed by this host must be declared in the PCD as a PK device type. Each unit declared must be assigned a Unit Number in the PCD that corresponds to the partition number in the DSI3200 as defined above. The Unit Number/LUN will be unique for each partition configured in the DSI3200. The unit is configured to be attached to one or more Controls as defined above.

A single unit/partition may be configured to be accessed by up to 4 Controls. This is known as multi-porting. When multi-porting is configured on the DSI3200, the same unit must be declared as accessed by the appropriate port/Control.

### Example #1

In the following example, a DSI3200 with 16GB of memory is partitioned into two (2) 8GB units. A single FCA6x2-SW channel accesses each unit. The DSI3200 has a single, 2 port Fibre Channel interface card.

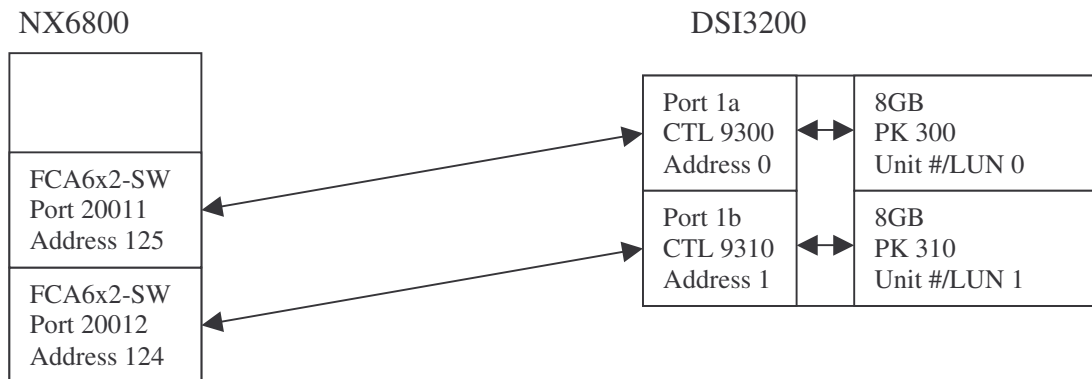

In the example above example, the devices would be declared with the following attributes. Device numbers are only for example and will vary from site to site.

Port 20011: Type SCSI, SCSI Address 125 (other attributes configuration dependent)

Port 20012: Type SCSI, SCSI Address 124 (other attributes configuration dependent)

Control 9300: Type FCSCSI1, SCSI Address 0, attached to port 20011

Control 9310: Type FCSCSI1, SCSI Address 1, attached to port 20012

Unit 300: Type PK, Unit Number 0, attached to Control 9300

Unit 310: Type PK, Unit Number 1, attached to Control 9310

### Example #2

In the following example, a DSI3200 with 24GB of memory is partitioned into two (2) 12GB units. Two FCA6x2-SW channels access each unit. This is a dual port disk scenario. The DSI3200 has two, 2 port, Fibre Channel interface cards. The second port on each interface card is not used.

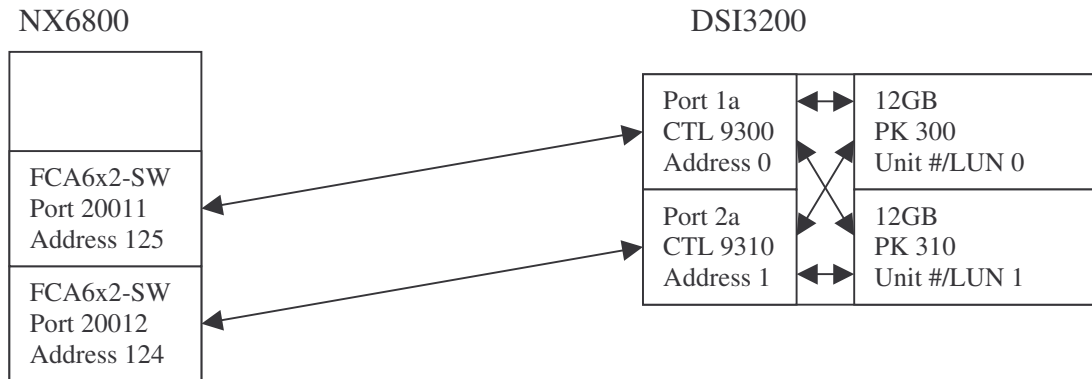

In the example above example, the devices would be declared with the following attributes. Device numbers are only for example and will vary from site to site.

Port 20011: Type SCSI, SCSI Address 125 (other attributes configuration dependent)

Port 20012: Type SCSI, SCSI Address 124 (other attributes configuration dependent)

Control 9300: Type FCSCSI1, SCSI Address 0, attached to port 20011

Control 9310: Type FCSCSI1, SCSI Address 1, attached to port 20012

Unit 300: Type PK, Unit Number 0, attached to Control 9300 and 9310

Unit 310: Type PK, Unit Number 1, attached to Control 9300 and 9310

## MCP Initialization and Use

DSI will prepare the DSI3200 for MCP use if configuration information is received. If the DSI3200 configuration is changed in the field, each partition (PK) must be initialized and reconfigured by the MCP before use. It is recommended that the units be initialized as VSS1 unit to conserve storage space. The following are examples of the commands used to prepare the unit for MCP use.

```
INITIALIZE PK 300 VSS = VSS1
```

```
RC PK 300 NAME = SSDPACK, SERIAL = 123456
```

DSI3200 packs may also be mirrored with other SSD or rotational disks as allowed by Unisys MCP mirror pack rules. If a rotational disk is used as a mirror of a DSI3200 pack, it is highly recommended that the rotational disk member of the mirror be marked as a remote disk for the best performance.

```
REMOTEDISK + PK400
```

## Configuring Ethernet Settings

The DSI3200 allows system monitoring and configuration through the serial port and the Ethernet port. To access the system's Ethernet port, the administrator must assign the DSI3200 an IP address, subnet mask, and possibly a gateway. The administrator may assign the IP address in one of three ways: Static IP, DHCP, or No Ethernet.

**\*\*The DSI3200 must be assigned an IP address and be accessible through Telnet or the Web Interface before contacting DSI for any support. \*\***

For any questions regarding IP assignment values, please consult your network administrator.

### Configuring Ethernet Settings via Front Panel

To setup the Ethernet via the Front Panel, use the arrow buttons to cycle through the top-level menu options until the display shows "**Ethernet Setup.**" Use the **Select** button to choose this option and continue with the configuration. You may now use the arrow buttons to scroll through the following menu options:

- Displays a list of the current IP configuration, hostname, IP address, subnet mask, gateway address (if applicable), and hardware Ethernet address.
- To continue setting up the Ethernet configuration
- Shuts down and restarts the Ethernet port using the current IP assignment configuration
- Exits the setup menu.

Show Current Config

Set IP Config

Restart Network

Exit Menu

Use the arrow buttons to scroll up and down through the list. Pressing the "**Menu**" button returns to the previous menu, and pressing the "**Select**" button exits the menu system. To continue setting up the Ethernet configuration, select "**Set IP Config.**"

After selecting "**Set IP Config,**" you may use the arrow buttons to cycle through:

- Enables you to set a static IP address for the DSI3200.
- Sets the IP configuration to DHCP

Static

DHCP

- Disables Ethernet

None

- Returns to the Main Menu without making any changes

No change

Talk to your network administrator for the proper IP assignment type. The default factory setting is DHCP. Use the "**Select**" button to select the desired method of IP assignment. If you did not choose "**Static IP**" you are asked to confirm the selection with the "↓" button.

To configure the DSI3200 with a static IP, the system requires the IP address, subnet mask, and a possibly a gateway address.

After you have chosen "**Static IP**," "**Ethernet IP**" replaces the top line of the display, and the display prompts you to enter an IP. Use the "↑" or "↓" buttons to cycle through the numbers "0" through "9". To select the value, use the "**Select**" button. Then, the input prompt moves to the next character position. To back up a space, press the "↑" and "↓" button simultaneously. Repeat this procedure until you have entered the 4-byte address. Press the "**Menu**" button at any time to cancel the Static IP assignment.

Ethernet IP

—

After you have finished entering the IP, the top line of the front panel changes to "**Subnet Mask**." Using the same procedure as entering the IP address, enter the subnet mask.

Subnet Mask

—

The final value you must enter is the "**Gateway Address**." If the DSI3200 is on a private network and this value is not needed, enter the value "**0.0.0.0**" to tell the DSI3200 to ignore this entry.

Gateway Address

—

After entering all three values, the display prompts you to confirm the command with the "↓" button.

After confirming the new IP assignment mode, the display indicates "**Shutting Down Network...**" followed by a success or failure message. Then, the display indicates "**Saving IP Config...**" followed by a success or failure message. Next, the DSI3200 attempts to start the network with the new settings, indicated on the front panel display with "**Restarting Network...**" Upon success, the system displays the new IP address on the front panel for 15 seconds or until any button is pressed.

Shutting Down Network...
Saving IP Config...
Restarting network...
New IP Address: 000.000.000.000

If the network fails to start, check the Ethernet connection and contact your system administrator. If the system successfully saved the IP configuration, you may simply select the "**Restart Network**" option from the "**Ethernet Setup**" menu instead of re-selecting the same IP configuration.

### DSI Support Team

Dynamic Solutions International  
(303) 754-2000  
[support@dynamicssolutions.com](mailto:support@dynamicssolutions.com)